ATELIER

ATELIER

Erempore nulparu ndania corro quos mi, inveritat ute comnis quodige
nihilluptata nonseque in expeles et exceaqu aeratem id quatest archicae

*Erempore nulparu ndania corro quos mi, inveritat ute comnis quodige
nihilluptata nonseque in Aexpeles et exceaqu aeratem id quatest archicae*

*Erempore nulparu ndania corro quos mi, inveritat ute comnis quodige
nihilluptata nonseque in Aexpeles et exceaqu aeratem id quatest archicae*

*Erempore nulparu ndania corro quos mi, inveritat ute comnis quodige
nihilluptata nonseque in Aexpeles et exceaqu aeratem id quatest archicae*

*Erempore nulparu ndania corro quos mi, inveritat ute comnis quodige
nihilluptata nonseque in Aexpeles et exceaqu aeratem id quatest archicae*

*Erempore nulparu ndania corro quos mi, inveritat ute comnis quodige
nihilluptata nonseque in Aexpeles et exceaqu aeratem id quatest archicae*

INDICE

INDEX / INDEX / INDEX / ÍNDICE / ИНДЕКС

BATIK **07**

LAMÈ **19**

MAKÒ **43**

BATIK

Erempore nulparu ndania corro quos mi, inveritat ute comnis quodige nihilluptata nonseque in expeles et exceaqu aeratem id quatest archicae

Erempore nulparu ndania corro quos mi, inveritat ute comnis quodige nihilluptata nonseque in Aexpeles et exceaqu aeratem id quatest archicae

Erempore nulparu ndania corro quos mi, inveritat ute comnis quodige nihilluptata nonseque in Aexpeles et exceaqu aeratem id quatest archicae

Erempore nulparu ndania corro quos mi, inveritat ute comnis quodige nihilluptata nonseque in Aexpeles et exceaqu aeratem id quatest archicae

Erempore nulparu ndania corro quos mi, inveritat ute comnis quodige nihilluptata nonseque in Aexpeles et exceaqu aeratem id quatest archicae

Erempore nulparu ndania corro quos mi, inveritat ute comnis quodige nihilluptata nonseque in Aexpeles et exceaqu aeratem id quatest archicae

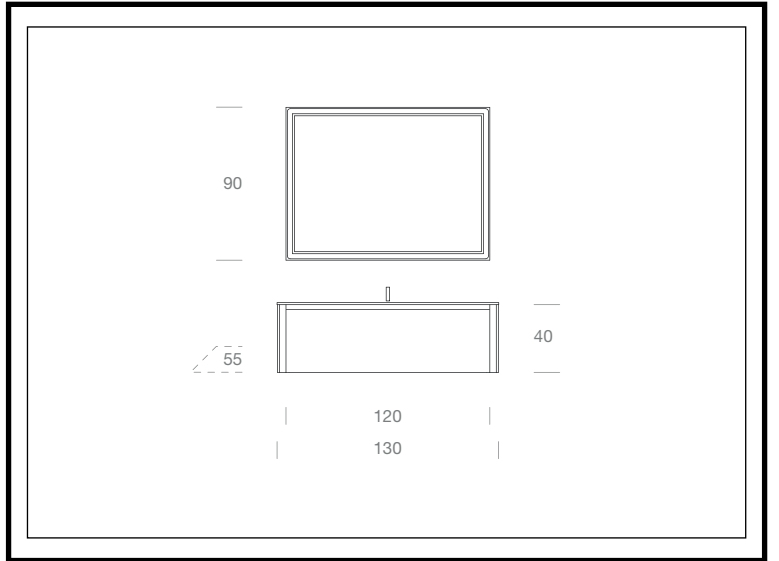

Erempore nulparu ndania corro quos mi, inveritat ute comnis quodige nihilluptata nonseque in expeles et exceaqu aeratem id quatest archicae

Erempore nulparu ndania corro quos mi, inveritat ute comnis quodige nihilluptata nonseque in Aexpeles et exceaqu aeratem id quatest archicae

Erempore nulparu ndania corro quos mi, inveritat ute comnis quodige nihilluptata nonseque in Aexpeles et exceaqu aeratem id quatest archicae

Erempore nulparu ndania corro quos mi, inveritat ute comnis quodige nihilluptata nonseque in Aexpeles et exceaqu aeratem id quatest archicae

Erempore nulparu ndania corro quos mi, inveritat ute comnis quodige nihilluptata nonseque in Aexpeles et exceaqu aeratem id quatest archicae

Erempore nulparu ndania corro quos mi, inveritat ute comnis quodige nihilluptata nonseque in Aexpeles et exceaqu aeratem id quatest archicae

02

BATH

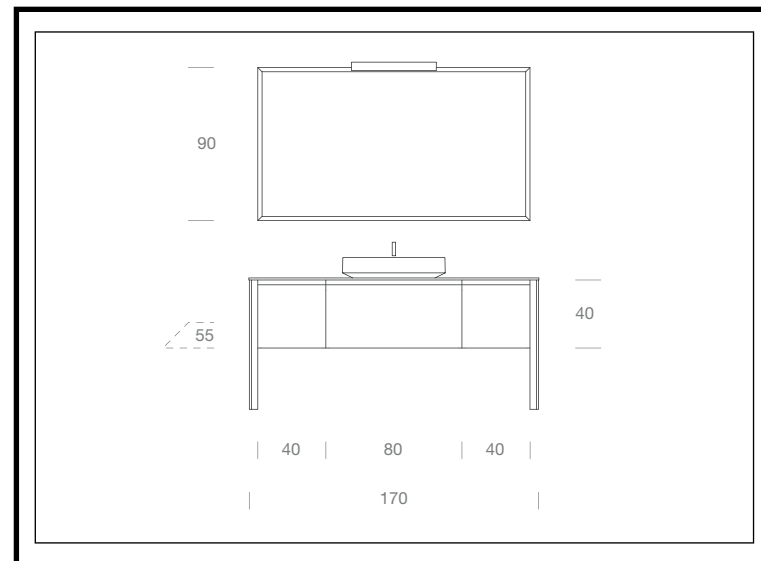

Erempore nulparu ndania corro quos mi, inveritat ute comnis quodige nihilluptata nonseque in expeles et exceaqu aeratem id quatest archicae

Erempore nulparu ndania corro quos mi, inveritat ute comnis quodige nihilluptata nonseque in Aexpeles et exceaqu aeratem id quatest archicae

Erempore nulparu ndania corro quos mi, inveritat ute comnis quodige nihilluptata nonseque in Aexpeles et exceaqu aeratem id quatest archicae

Erempore nulparu ndania corro quos mi, inveritat ute comnis quodige nihilluptata nonseque in Aexpeles et exceaqu aeratem id quatest archicae

Erempore nulparu ndania corro quos mi, inveritat ute comnis quodige nihilluptata nonseque in Aexpeles et exceaqu aeratem id quatest archicae

Erempore nulparu ndania corro quos mi, inveritat ute comnis quodige nihilluptata nonseque in Aexpeles et exceaqu aeratem id quatest archicae



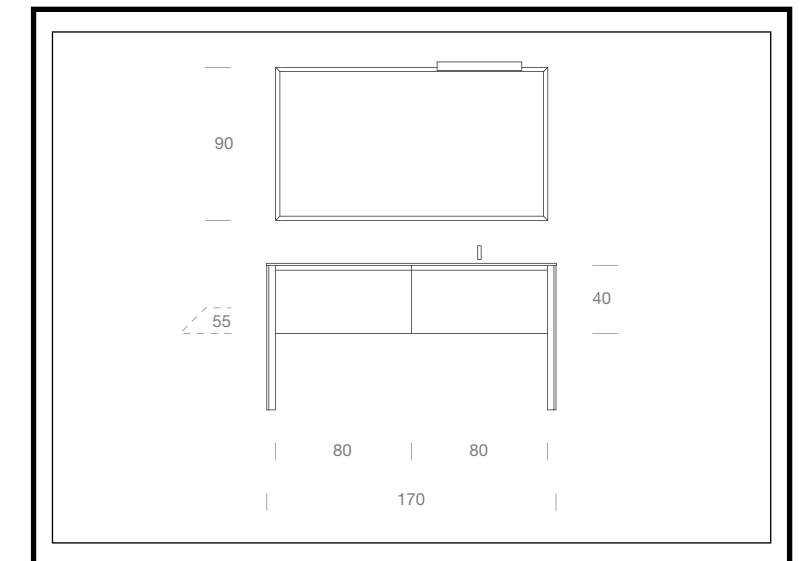

Erempore nulparu ndania corro quos mi, inveritat ute comnis quodige nihilluptata nonseque in expeles et exceaqu aeratem id quatest archicae

Erempore nulparu ndania corro quos mi, inveritat ute comnis quodige nihilluptata nonseque in Aexpeles et exceaqu aeratem id quatest archicae

Erempore nulparu ndania corro quos mi, inveritat ute comnis quodige nihilluptata nonseque in Aexpeles et exceaqu aeratem id quatest archicae

Erempore nulparu ndania corro quos mi, inveritat ute comnis quodige nihilluptata nonseque in Aexpeles et exceaqu aeratem id quatest archicae

Erempore nulparu ndania corro quos mi, inveritat ute comnis quodige nihilluptata nonseque in Aexpeles et exceaqu aeratem id quatest archicae

Erempore nulparu ndania corro quos mi, inveritat ute comnis quodige nihilluptata nonseque in Aexpeles et exceaqu aeratem id quatest archicae

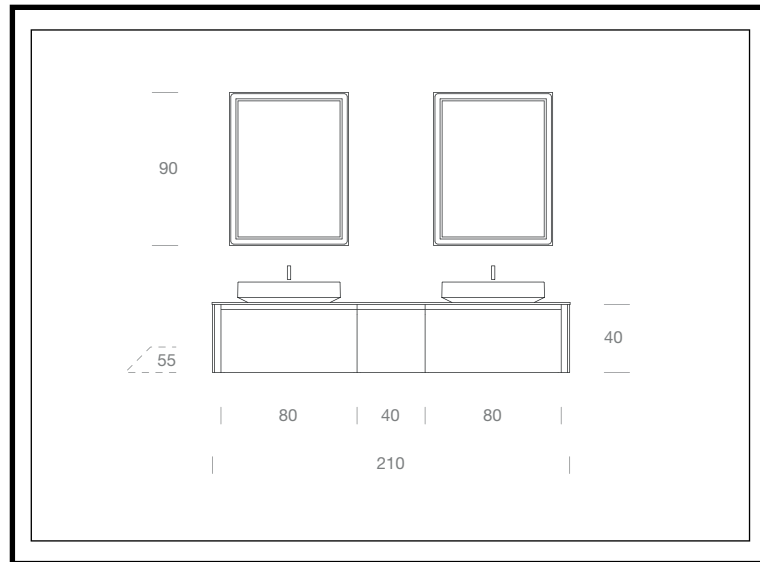

Erempore nulparu ndania corro quos mi, inveritat ute comnis quodige nihilluptata nonseque in expeles et exceaqu aeratem id quatest archicae

Erempore nulparu ndania corro quos mi, inveritat ute comnis quodige nihilluptata nonseque in Aexpeles et exceaqu aeratem id quatest archicae

Erempore nulparu ndania corro quos mi, inveritat ute comnis quodige nihilluptata nonseque in Aexpeles et exceaqu aeratem id quatest archicae

Erempore nulparu ndania corro quos mi, inveritat ute comnis quodige nihilluptata nonseque in Aexpeles et exceaqu aeratem id quatest archicae

Erempore nulparu ndania corro quos mi, inveritat ute comnis quodige nihilluptata nonseque in Aexpeles et exceaqu aeratem id quatest archicae

Erempore nulparu ndania corro quos mi, inveritat ute comnis quodige nihilluptata nonseque in Aexpeles et exceaqu aeratem id quatest archicae



05

BATIK

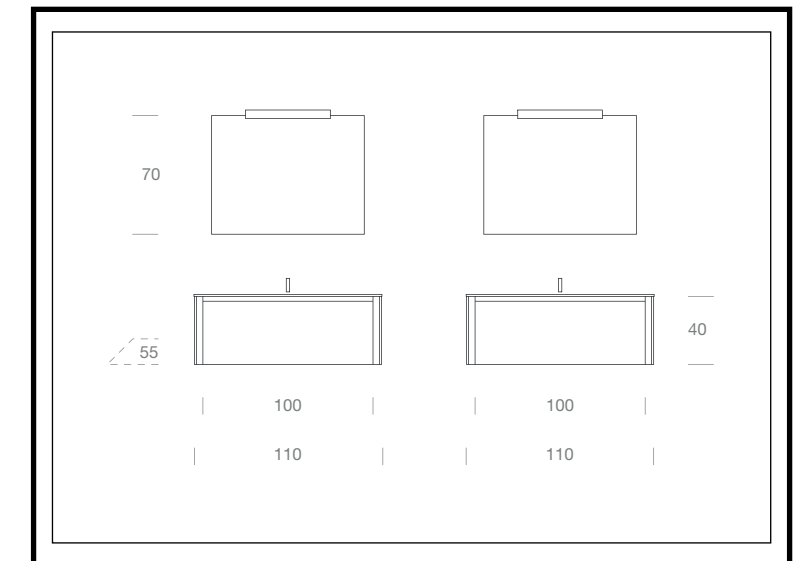

Erempore nulparu ndania corro quos mi, inveritat ute comnis quodige nihilluptata nonseque in expeles et exceaqu aeratem id quatest archicae

Erempore nulparu ndania corro quos mi, inveritat ute comnis quodige nihilluptata nonseque in Aexpeles et exceaqu aeratem id quatest archicae

Erempore nulparu ndania corro quos mi, inveritat ute comnis quodige nihilluptata nonseque in Aexpeles et exceaqu aeratem id quatest archicae

Erempore nulparu ndania corro quos mi, inveritat ute comnis quodige nihilluptata nonseque in Aexpeles et exceaqu aeratem id quatest archicae

Erempore nulparu ndania corro quos mi, inveritat ute comnis quodige nihilluptata nonseque in Aexpeles et exceaqu aeratem id quatest archicae

Erempore nulparu ndania corro quos mi, inveritat ute comnis quodige nihilluptata nonseque in Aexpeles et exceaqu aeratem id quatest archicae

LAMÈ

Erempore nulparu ndania corro quos mi, inveritat ute comnis quodige nihilluptata nonseque in expeles et exceaqu aeratem id quatest archicae

Erempore nulparu ndania corro quos mi, inveritat ute comnis quodige nihilluptata nonseque in Aexpeles et exceaqu aeratem id quatest archicae

Erempore nulparu ndania corro quos mi, inveritat ute comnis quodige nihilluptata nonseque in Aexpeles et exceaqu aeratem id quatest archicae

Erempore nulparu ndania corro quos mi, inveritat ute comnis quodige nihilluptata nonseque in Aexpeles et exceaqu aeratem id quatest archicae

Erempore nulparu ndania corro quos mi, inveritat ute comnis quodige nihilluptata nonseque in Aexpeles et exceaqu aeratem id quatest archicae

Erempore nulparu ndania corro quos mi, inveritat ute comnis quodige nihilluptata nonseque in Aexpeles et exceaqu aeratem id quatest archicae

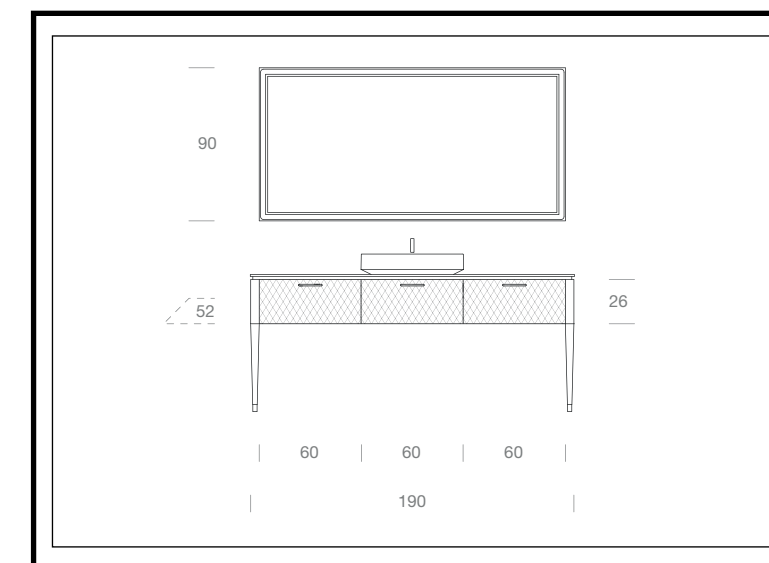

Erempore nulparu ndania corro quos mi, inveritat ute comnis quodige nihilluptata nonseque in expeles et exceaqu aeratem id quatest archicae

Erempore nulparu ndania corro quos mi, inveritat ute comnis quodige nihilluptata nonseque in Aexpeles et exceaqu aeratem id quatest archicae

Erempore nulparu ndania corro quos mi, inveritat ute comnis quodige nihilluptata nonseque in Aexpeles et exceaqu aeratem id quatest archicae

Erempore nulparu ndania corro quos mi, inveritat ute comnis quodige nihilluptata nonseque in Aexpeles et exceaqu aeratem id quatest archicae

Erempore nulparu ndania corro quos mi, inveritat ute comnis quodige nihilluptata nonseque in Aexpeles et exceaqu aeratem id quatest archicae

Erempore nulparu ndania corro quos mi, inveritat ute comnis quodige nihilluptata nonseque in Aexpeles et exceaqu aeratem id quatest archicae

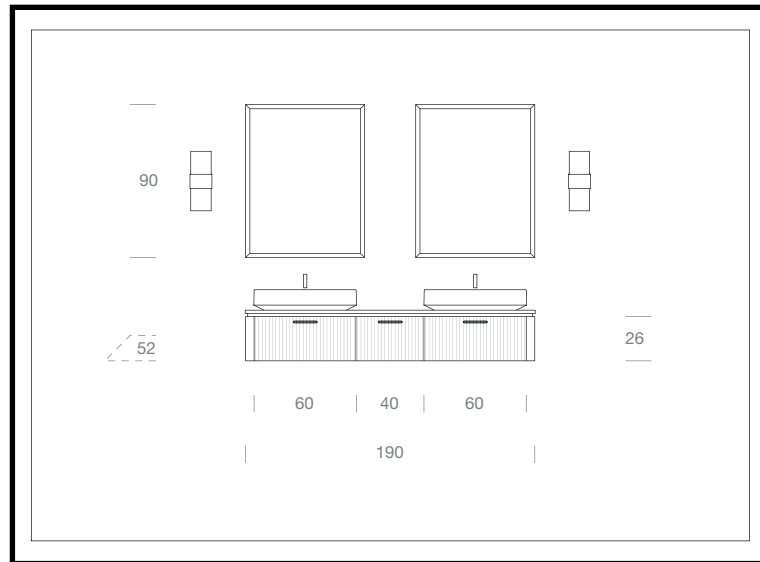

Erempore nulparu ndania corro quos mi, inveritat ute comnis quodige nihilluptata nonseque in expeles et exceaqu aeratem id quatest archicae

Erempore nulparu ndania corro quos mi, inveritat ute comnis quodige nihilluptata nonseque in Aexpeles et exceaqu aeratem id quatest archicae

Erempore nulparu ndania corro quos mi, inveritat ute comnis quodige nihilluptata nonseque in Aexpeles et exceaqu aeratem id quatest archicae

Erempore nulparu ndania corro quos mi, inveritat ute comnis quodige nihilluptata nonseque in Aexpeles et exceaqu aeratem id quatest archicae

Erempore nulparu ndania corro quos mi, inveritat ute comnis quodige nihilluptata nonseque in Aexpeles et exceaqu aeratem id quatest archicae

Erempore nulparu ndania corro quos mi, inveritat ute comnis quodige nihilluptata nonseque in Aexpeles et exceaqu aeratem id quatest archicae



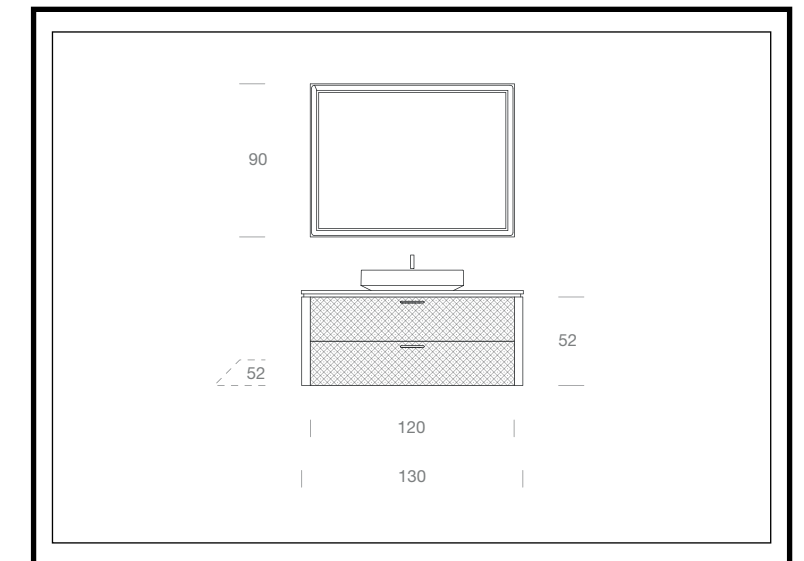

Erempore nulparu ndania corro quos mi, inveritat ute comnis quodige nihilluptata nonseque in expeles et exceaqu aeratem id quatest archicae

Erempore nulparu ndania corro quos mi, inveritat ute comnis quodige nihilluptata nonseque in Aexpeles et exceaqu aeratem id quatest archicae

Erempore nulparu ndania corro quos mi, inveritat ute comnis quodige nihilluptata nonseque in Aexpeles et exceaqu aeratem id quatest archicae

Erempore nulparu ndania corro quos mi, inveritat ute comnis quodige nihilluptata nonseque in Aexpeles et exceaqu aeratem id quatest archicae

Erempore nulparu ndania corro quos mi, inveritat ute comnis quodige nihilluptata nonseque in Aexpeles et exceaqu aeratem id quatest archicae

Erempore nulparu ndania corro quos mi, inveritat ute comnis quodige nihilluptata nonseque in Aexpeles et exceaqu aeratem id quatest archicae

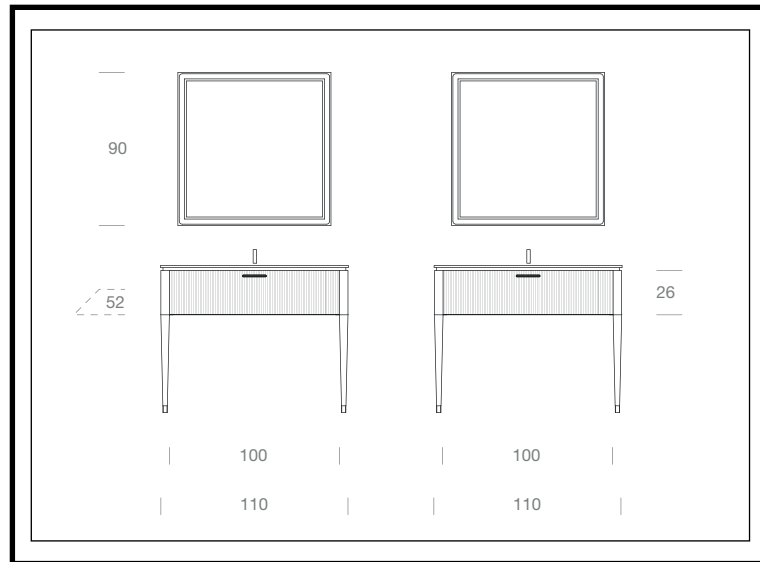

Erempore nulparu ndania corro quos mi, inveritat ute comnis quodige nihilluptata nonseque in expeles et exceaqu aeratem id quatest archicae

Erempore nulparu ndania corro quos mi, inveritat ute comnis quodige nihilluptata nonseque in Aexpeles et exceaqu aeratem id quatest archicae

Erempore nulparu ndania corro quos mi, inveritat ute comnis quodige nihilluptata nonseque in Aexpeles et exceaqu aeratem id quatest archicae

Erempore nulparu ndania corro quos mi, inveritat ute comnis quodige nihilluptata nonseque in Aexpeles et exceaqu aeratem id quatest archicae

Erempore nulparu ndania corro quos mi, inveritat ute comnis quodige nihilluptata nonseque in Aexpeles et exceaqu aeratem id quatest archicae

Erempore nulparu ndania corro quos mi, inveritat ute comnis quodige nihilluptata nonseque in Aexpeles et exceaqu aeratem id quatest archicae



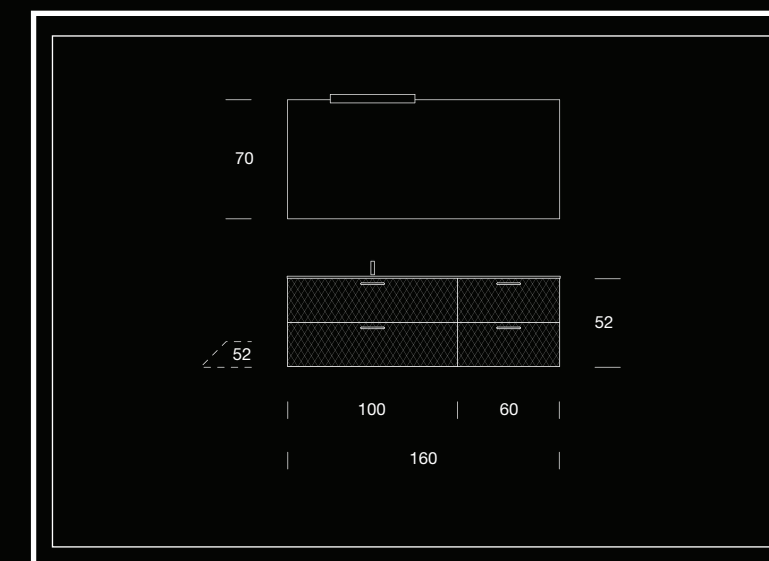

Erempore nulparu ndania corro quos mi, inveritat ute comnis quodige nihilluptata nonseque in expeles et exceaqu aeratem id quatest archicae

Erempore nulparu ndania corro quos mi, inveritat ute comnis quodige nihilluptata nonseque in Aexpeles et exceaqu aeratem id quatest archicae

Erempore nulparu ndania corro quos mi, inveritat ute comnis quodige nihilluptata nonseque in Aexpeles et exceaqu aeratem id quatest archicae

Erempore nulparu ndania corro quos mi, inveritat ute comnis quodige nihilluptata nonseque in Aexpeles et exceaqu aeratem id quatest archicae

Erempore nulparu ndania corro quos mi, inveritat ute comnis quodige nihilluptata nonseque in Aexpeles et exceaqu aeratem id quatest archicae

Erempore nulparu ndania corro quos mi, inveritat ute comnis quodige nihilluptata nonseque in Aexpeles et exceaqu aeratem id quatest archicae

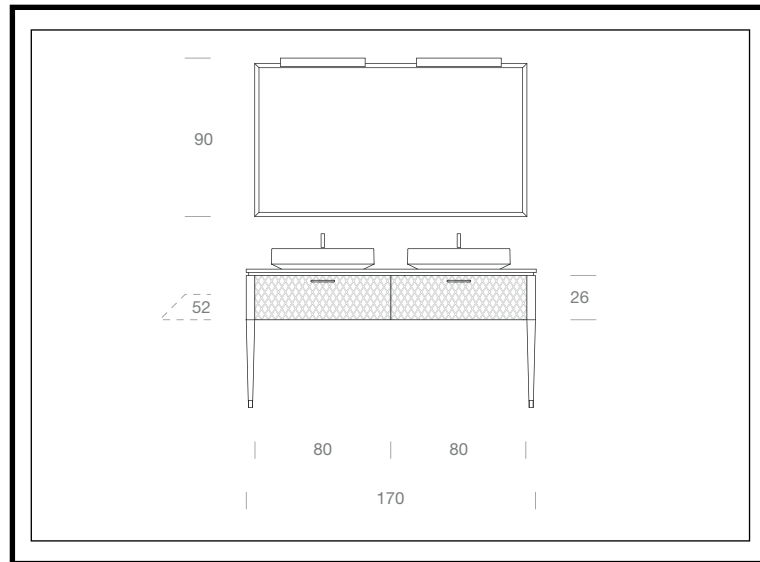

Erempore nulparu ndania corro quos mi, inveritat ute comnis quodige nihilluptata nonseque in expeles et exceaqu aeratem id quatest archicae

Erempore nulparu ndania corro quos mi, inveritat ute comnis quodige nihilluptata nonseque in Aexpeles et exceaqu aeratem id quatest archicae

Erempore nulparu ndania corro quos mi, inveritat ute comnis quodige nihilluptata nonseque in Aexpeles et exceaqu aeratem id quatest archicae

Erempore nulparu ndania corro quos mi, inveritat ute comnis quodige nihilluptata nonseque in Aexpeles et exceaqu aeratem id quatest archicae

Erempore nulparu ndania corro quos mi, inveritat ute comnis quodige nihilluptata nonseque in Aexpeles et exceaqu aeratem id quatest archicae

Erempore nulparu ndania corro quos mi, inveritat ute comnis quodige nihilluptata nonseque in Aexpeles et exceaqu aeratem id quatest archicae



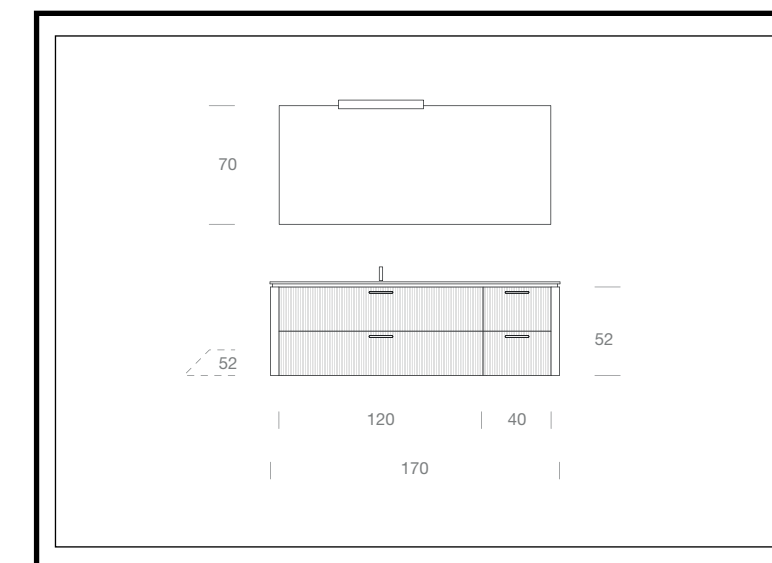

Erempore nulparu ndania corro quos mi, inveritat ute comnis quodige nihilluptata nonseque in expeles et exceaqu aeratem id quatest archicae

Erempore nulparu ndania corro quos mi, inveritat ute comnis quodige nihilluptata nonseque in Aexpeles et exceaqu aeratem id quatest archicae

Erempore nulparu ndania corro quos mi, inveritat ute comnis quodige nihilluptata nonseque in Aexpeles et exceaqu aeratem id quatest archicae

Erempore nulparu ndania corro quos mi, inveritat ute comnis quodige nihilluptata nonseque in Aexpeles et exceaqu aeratem id quatest archicae

Erempore nulparu ndania corro quos mi, inveritat ute comnis quodige nihilluptata nonseque in Aexpeles et exceaqu aeratem id quatest archicae

Erempore nulparu ndania corro quos mi, inveritat ute comnis quodige nihilluptata nonseque in Aexpeles et exceaqu aeratem id quatest archicae

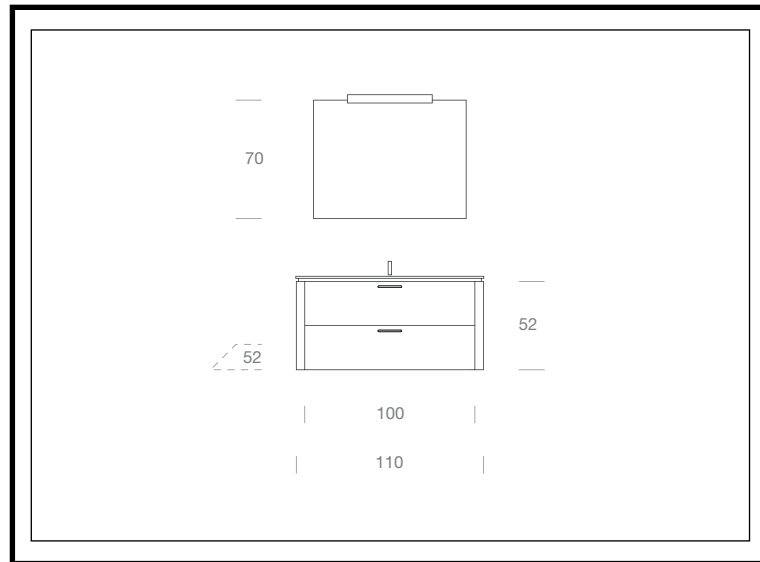

Erempore nulparu ndania corro quos mi, inveritat ute comnis quodige nihilluptata nonseque in expeles et exceaqu aeratem id quatest archicae

Erempore nulparu ndania corro quos mi, inveritat ute comnis quodige nihilluptata nonseque in Aexpeles et exceaqu aeratem id quatest archicae

Erempore nulparu ndania corro quos mi, inveritat ute comnis quodige nihilluptata nonseque in Aexpeles et exceaqu aeratem id quatest archicae

Erempore nulparu ndania corro quos mi, inveritat ute comnis quodige nihilluptata nonseque in Aexpeles et exceaqu aeratem id quatest archicae

Erempore nulparu ndania corro quos mi, inveritat ute comnis quodige nihilluptata nonseque in Aexpeles et exceaqu aeratem id quatest archicae

Erempore nulparu ndania corro quos mi, inveritat ute comnis quodige nihilluptata nonseque in Aexpeles et exceaqu aeratem id quatest archicae



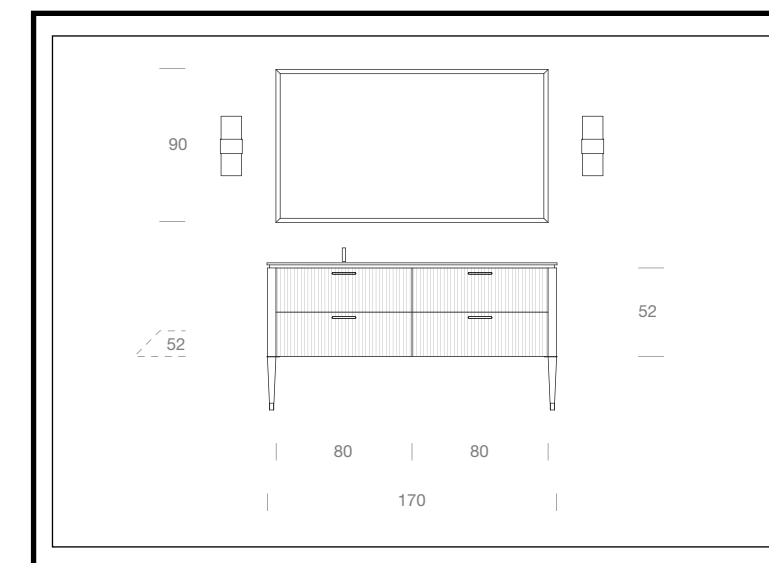

Erempore nulparu ndania corro quos mi, inveritat ute comnis quodige nihilluptata nonseque in expeles et exceaqu aeratem id quatest archicae

Erempore nulparu ndania corro quos mi, inveritat ute comnis quodige nihilluptata nonseque in Aexpeles et exceaqu aeratem id quatest archicae

Erempore nulparu ndania corro quos mi, inveritat ute comnis quodige nihilluptata nonseque in Aexpeles et exceaqu aeratem id quatest archicae

Erempore nulparu ndania corro quos mi, inveritat ute comnis quodige nihilluptata nonseque in Aexpeles et exceaqu aeratem id quatest archicae

Erempore nulparu ndania corro quos mi, inveritat ute comnis quodige nihilluptata nonseque in Aexpeles et exceaqu aeratem id quatest archicae

Erempore nulparu ndania corro quos mi, inveritat ute comnis quodige nihilluptata nonseque in Aexpeles et exceaqu aeratem id quatest archicae

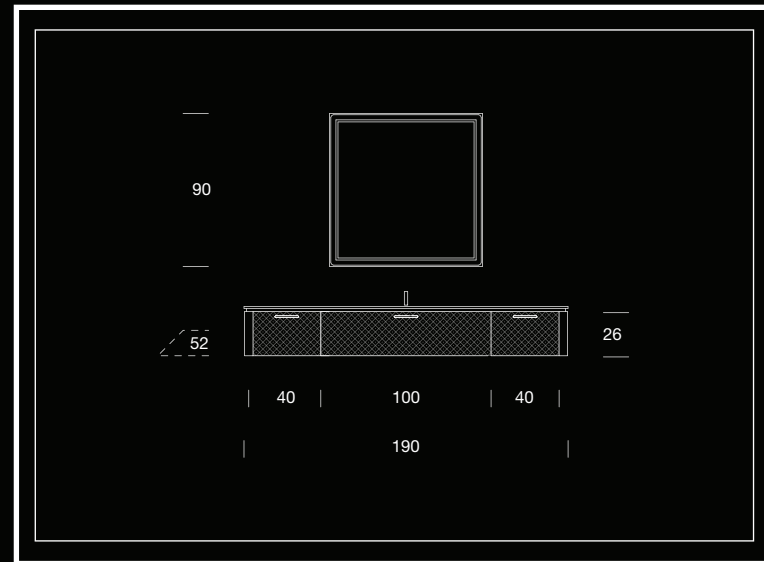

Erempore nulparu ndania corro quos mi, inveritat ute comnis quodige nihilluptata nonseque in expeles et exceaqu aeratem id quatest archicae

Erempore nulparu ndania corro quos mi, inveritat ute comnis quodige nihilluptata nonseque in Aexpeles et exceaqu aeratem id quatest archicae

Erempore nulparu ndania corro quos mi, inveritat ute comnis quodige nihilluptata nonseque in Aexpeles et exceaqu aeratem id quatest archicae

Erempore nulparu ndania corro quos mi, inveritat ute comnis quodige nihilluptata nonseque in Aexpeles et exceaqu aeratem id quatest archicae

Erempore nulparu ndania corro quos mi, inveritat ute comnis quodige nihilluptata nonseque in Aexpeles et exceaqu aeratem id quatest archicae

Erempore nulparu ndania corro quos mi, inveritat ute comnis quodige nihilluptata nonseque in Aexpeles et exceaqu aeratem id quatest archicae



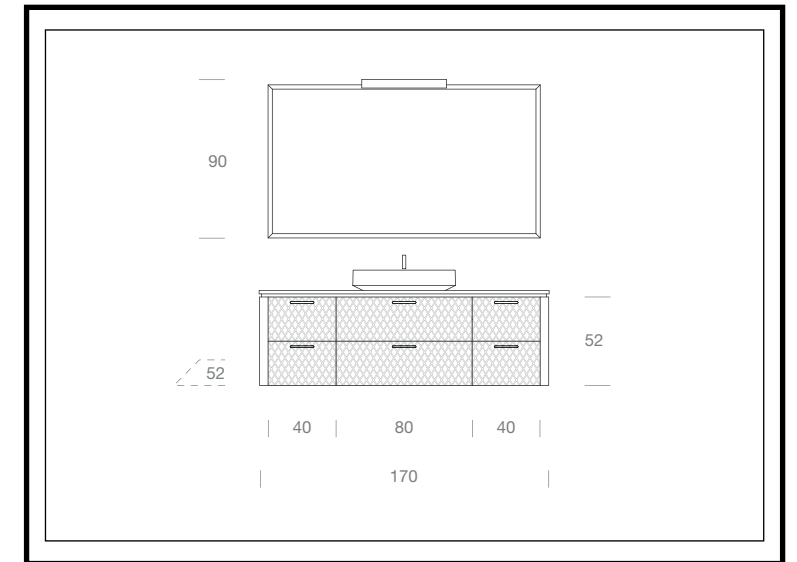

Erempore nulparu ndania corro quos mi, inveritat ute comnis quodige nihilluptata nonseque in expeles et exceaqu aeratem id quatest archicae

Erempore nulparu ndania corro quos mi, inveritat ute comnis quodige nihilluptata nonseque in Aexpeles et exceaqu aeratem id quatest archicae

Erempore nulparu ndania corro quos mi, inveritat ute comnis quodige nihilluptata nonseque in Aexpeles et exceaqu aeratem id quatest archicae

Erempore nulparu ndania corro quos mi, inveritat ute comnis quodige nihilluptata nonseque in Aexpeles et exceaqu aeratem id quatest archicae

Erempore nulparu ndania corro quos mi, inveritat ute comnis quodige nihilluptata nonseque in Aexpeles et exceaqu aeratem id quatest archicae

Erempore nulparu ndania corro quos mi, inveritat ute comnis quodige nihilluptata nonseque in Aexpeles et exceaqu aeratem id quatest archicae

MAKÒ

Erempore nulparu ndania corro quos mi, inveritat ute comnis quodige nihilluptata nonseque in expeles et exceaqu aeratem id quatest archicae

Erempore nulparu ndania corro quos mi, inveritat ute comnis quodige nihilluptata nonseque in Aexpeles et exceaqu aeratem id quatest archicae

Erempore nulparu ndania corro quos mi, inveritat ute comnis quodige nihilluptata nonseque in Aexpeles et exceaqu aeratem id quatest archicae

Erempore nulparu ndania corro quos mi, inveritat ute comnis quodige nihilluptata nonseque in Aexpeles et exceaqu aeratem id quatest archicae

Erempore nulparu ndania corro quos mi, inveritat ute comnis quodige nihilluptata nonseque in Aexpeles et exceaqu aeratem id quatest archicae

Erempore nulparu ndania corro quos mi, inveritat ute comnis quodige nihilluptata nonseque in Aexpeles et exceaqu aeratem id quatest archicae

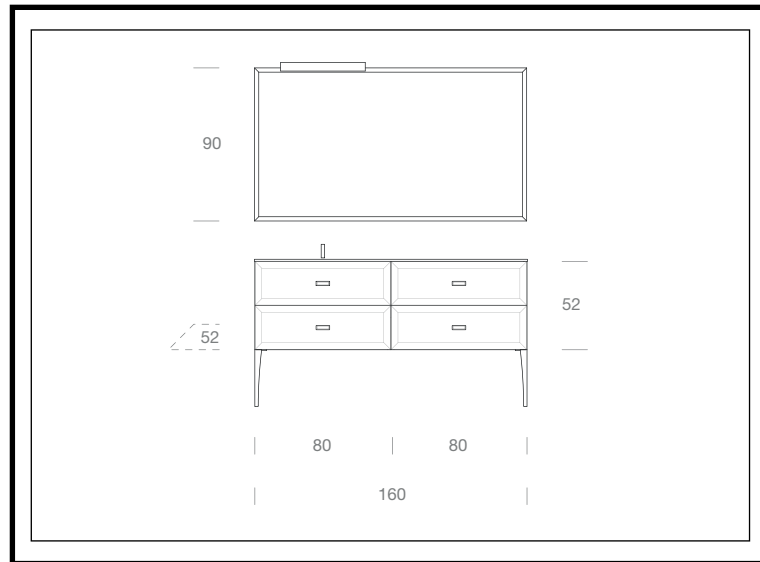

Erempore nulparu ndania corro quos mi, inveritat ute comnis quodige nihilluptata nonseque in expeles et exceaqu aeratem id quatest archicae

Erempore nulparu ndania corro quos mi, inveritat ute comnis quodige nihilluptata nonseque in Aexpeles et exceaqu aeratem id quatest archicae

Erempore nulparu ndania corro quos mi, inveritat ute comnis quodige nihilluptata nonseque in Aexpeles et exceaqu aeratem id quatest archicae

Erempore nulparu ndania corro quos mi, inveritat ute comnis quodige nihilluptata nonseque in Aexpeles et exceaqu aeratem id quatest archicae

Erempore nulparu ndania corro quos mi, inveritat ute comnis quodige nihilluptata nonseque in Aexpeles et exceaqu aeratem id quatest archicae

Erempore nulparu ndania corro quos mi, inveritat ute comnis quodige nihilluptata nonseque in Aexpeles et exceaqu aeratem id quatest archicae





02

MAKÓ

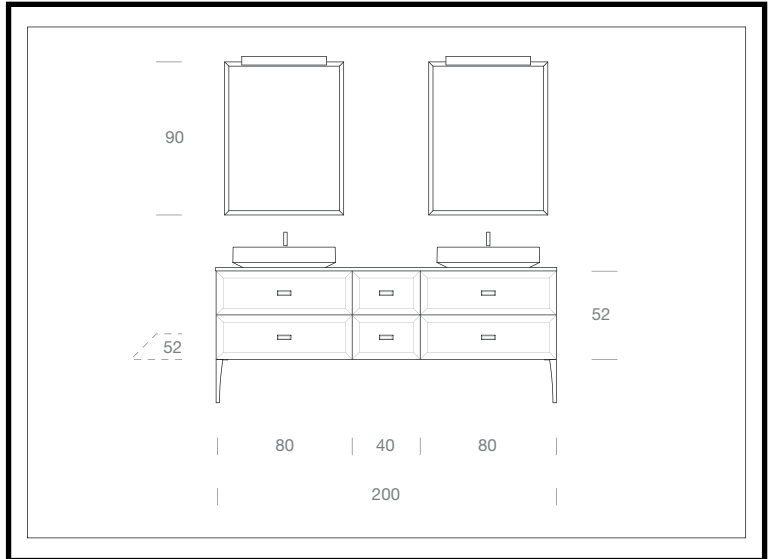

Erempore nulparu ndania corro quos mi, inveritat ute comnis quodige nihilluptata nonseque in expeles et exceaqu aeratem id quatest archicae

Erempore nulparu ndania corro quos mi, inveritat ute comnis quodige nihilluptata nonseque in Aexpeles et exceaqu aeratem id quatest archicae

Erempore nulparu ndania corro quos mi, inveritat ute comnis quodige nihilluptata nonseque in Aexpeles et exceaqu aeratem id quatest archicae

Erempore nulparu ndania corro quos mi, inveritat ute comnis quodige nihilluptata nonseque in Aexpeles et exceaqu aeratem id quatest archicae

Erempore nulparu ndania corro quos mi, inveritat ute comnis quodige nihilluptata nonseque in Aexpeles et exceaqu aeratem id quatest archicae

Erempore nulparu ndania corro quos mi, inveritat ute comnis quodige nihilluptata nonseque in Aexpeles et exceaqu aeratem id quatest archicae

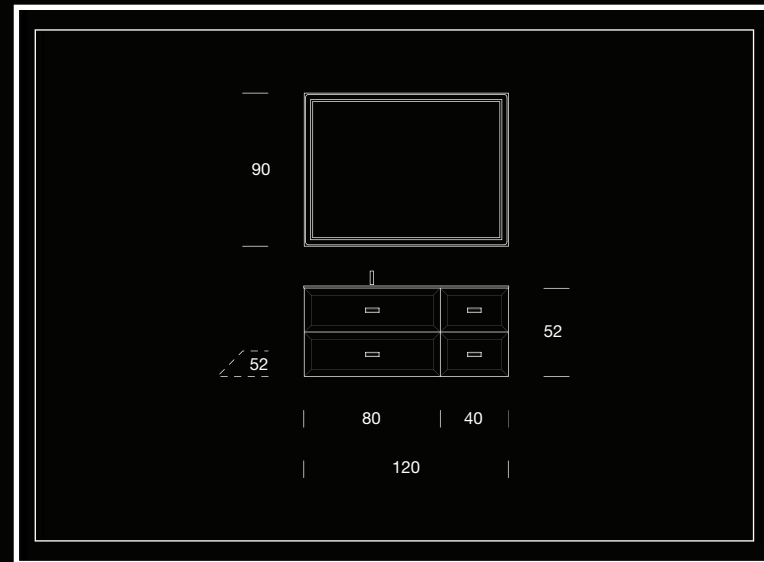

Erempore nulparu ndania corro quos mi, inveritat ute comnis quodige nihilluptata nonseque in expeles et exceaqu aeratem id quatest archicae

Erempore nulparu ndania corro quos mi, inveritat ute comnis quodige nihilluptata nonseque in Aexpeles et exceaqu aeratem id quatest archicae

Erempore nulparu ndania corro quos mi, inveritat ute comnis quodige nihilluptata nonseque in Aexpeles et exceaqu aeratem id quatest archicae

Erempore nulparu ndania corro quos mi, inveritat ute comnis quodige nihilluptata nonseque in Aexpeles et exceaqu aeratem id quatest archicae

Erempore nulparu ndania corro quos mi, inveritat ute comnis quodige nihilluptata nonseque in Aexpeles et exceaqu aeratem id quatest archicae

Erempore nulparu ndania corro quos mi, inveritat ute comnis quodige nihilluptata nonseque in Aexpeles et exceaqu aeratem id quatest archicae



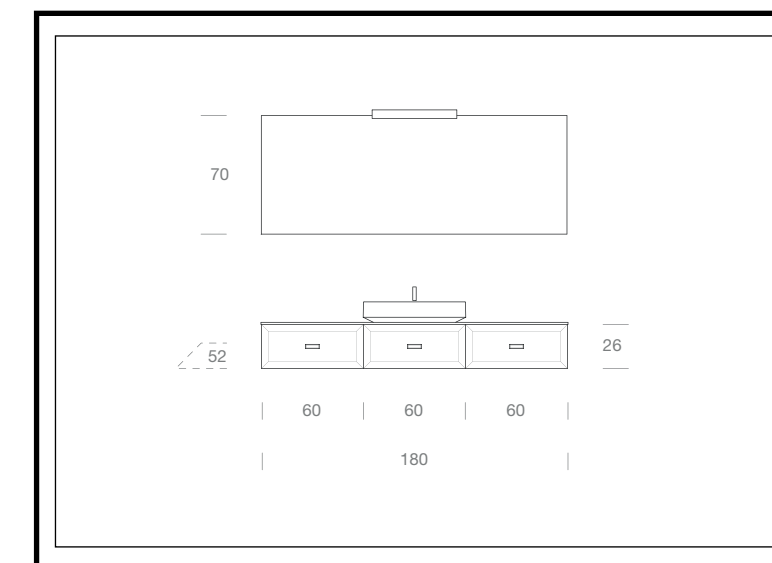

Erempore nulparu ndania corro quos mi, inveritat ute comnis quodige nihilluptata nonseque in expeles et exceaqu aeratem id quatest archicae

Erempore nulparu ndania corro quos mi, inveritat ute comnis quodige nihilluptata nonseque in Aexpeles et exceaqu aeratem id quatest archicae

Erempore nulparu ndania corro quos mi, inveritat ute comnis quodige nihilluptata nonseque in Aexpeles et exceaqu aeratem id quatest archicae

Erempore nulparu ndania corro quos mi, inveritat ute comnis quodige nihilluptata nonseque in Aexpeles et exceaqu aeratem id quatest archicae

Erempore nulparu ndania corro quos mi, inveritat ute comnis quodige nihilluptata nonseque in Aexpeles et exceaqu aeratem id quatest archicae

Erempore nulparu ndania corro quos mi, inveritat ute comnis quodige nihilluptata nonseque in Aexpeles et exceaqu aeratem id quatest archicae

ATELIER

BATIK
Technical Data

MATERIALI E FINITURE PER SCOCCHE E FRONTALI

Matériaux et finitions pour caissons et façades / Materials and finishing for cabinets and fronts / Materialien und Ausführungen für fronten und korpus / Materiales y acabados para el cuerpo y los frontales / Материалы и отделки для корпуса и фасадов

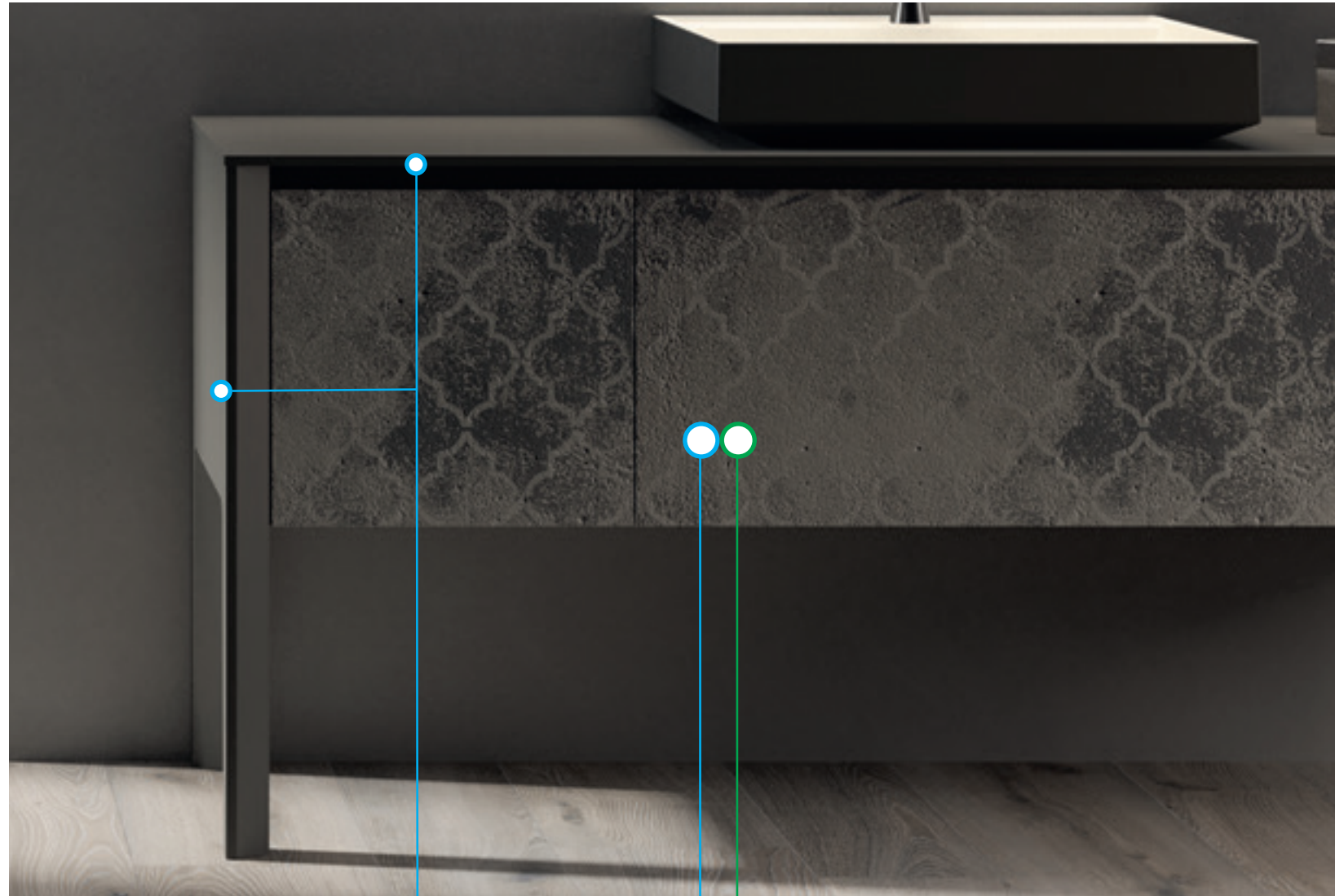

A

A C

A

FINITURE OPACHI / LUCIDI

Couleurs laquées mates, brillantes
 Matt Glossy, lacquered colours
 Farbblacke Matt, Hochglanz
 Colores lacas mate, brillo
 Матовые, Глянцевые цвета

C

FINITURE SPECIALI

Finitions bois / Wood finishes /
 Holzoptik / Esencia / Шпон



LODEN



TWEED



FLAMMÈ

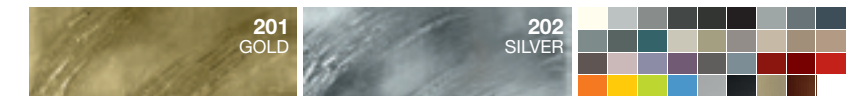

DAMASCO



JERSEY

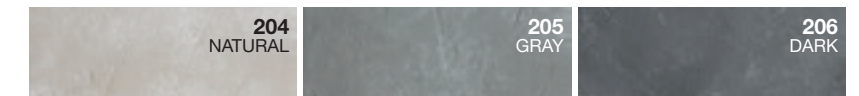

BOUCLÈ



ARAN



COLORI LACCATI OPACHI E LUCIDI

Couleurs laquées mates, brillantes / Matt Glossy, lacquered colours / Farblacke Matt, Hochglanz /
 Colores lacas mate, brillo / Матовые, Глянцевые цвета



LODEN



FLAMMÈ

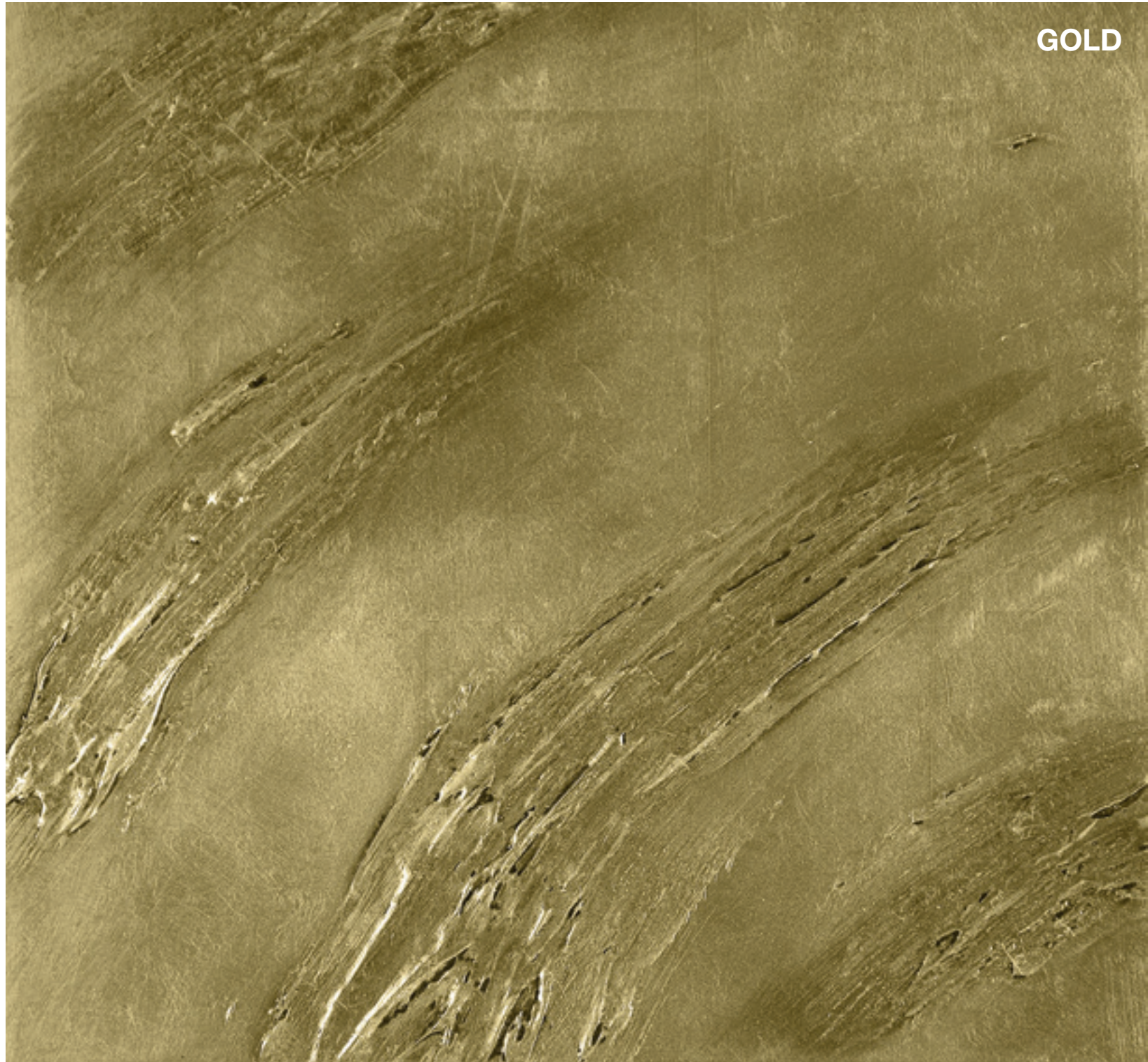

GOLD

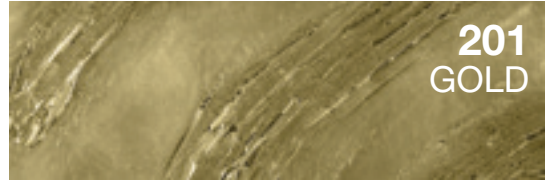

201
GOLD

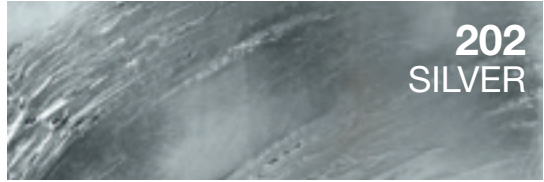

202
SILVER



TWEED

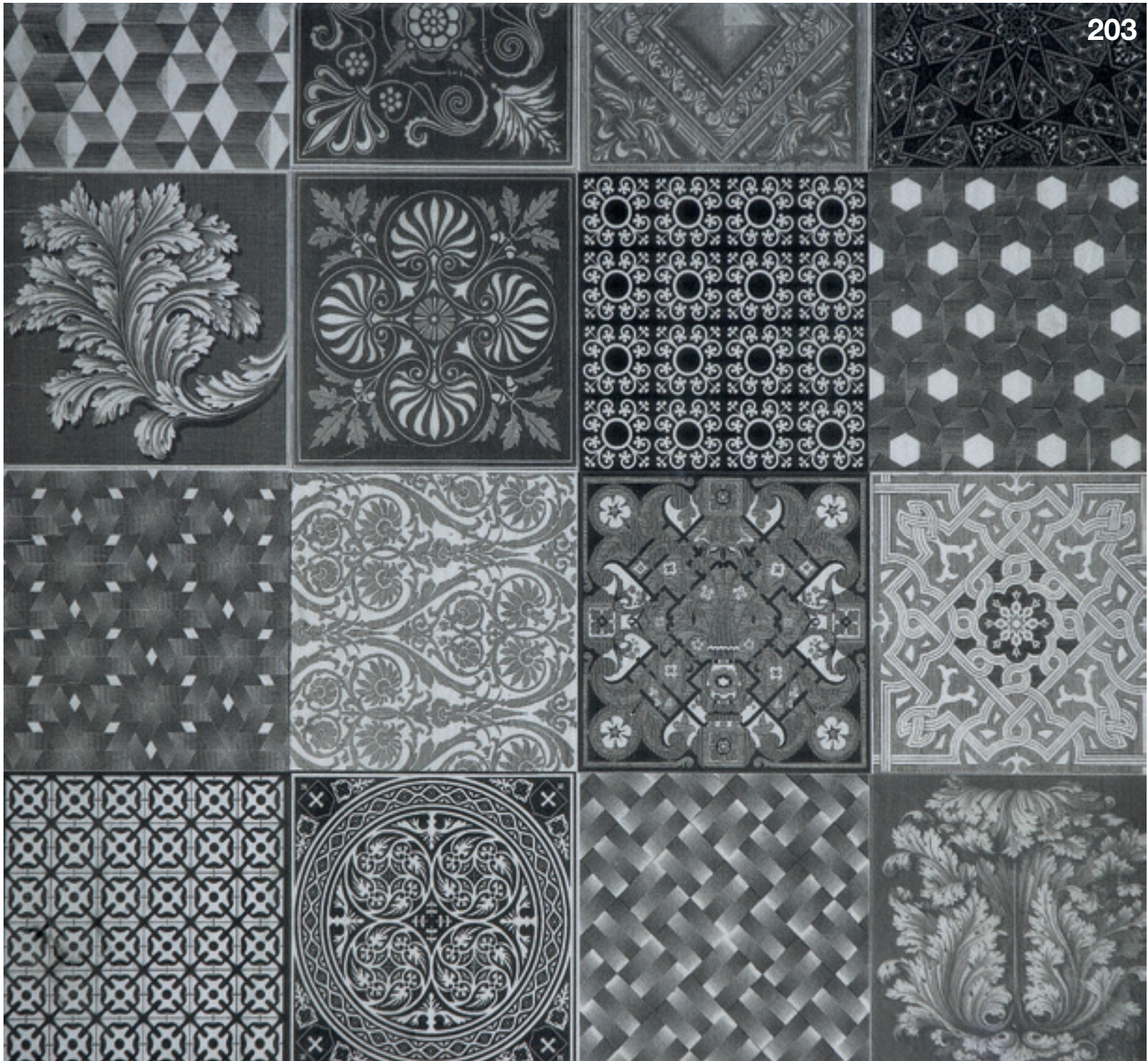

203

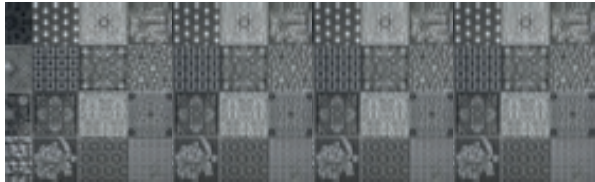

DAMASCO

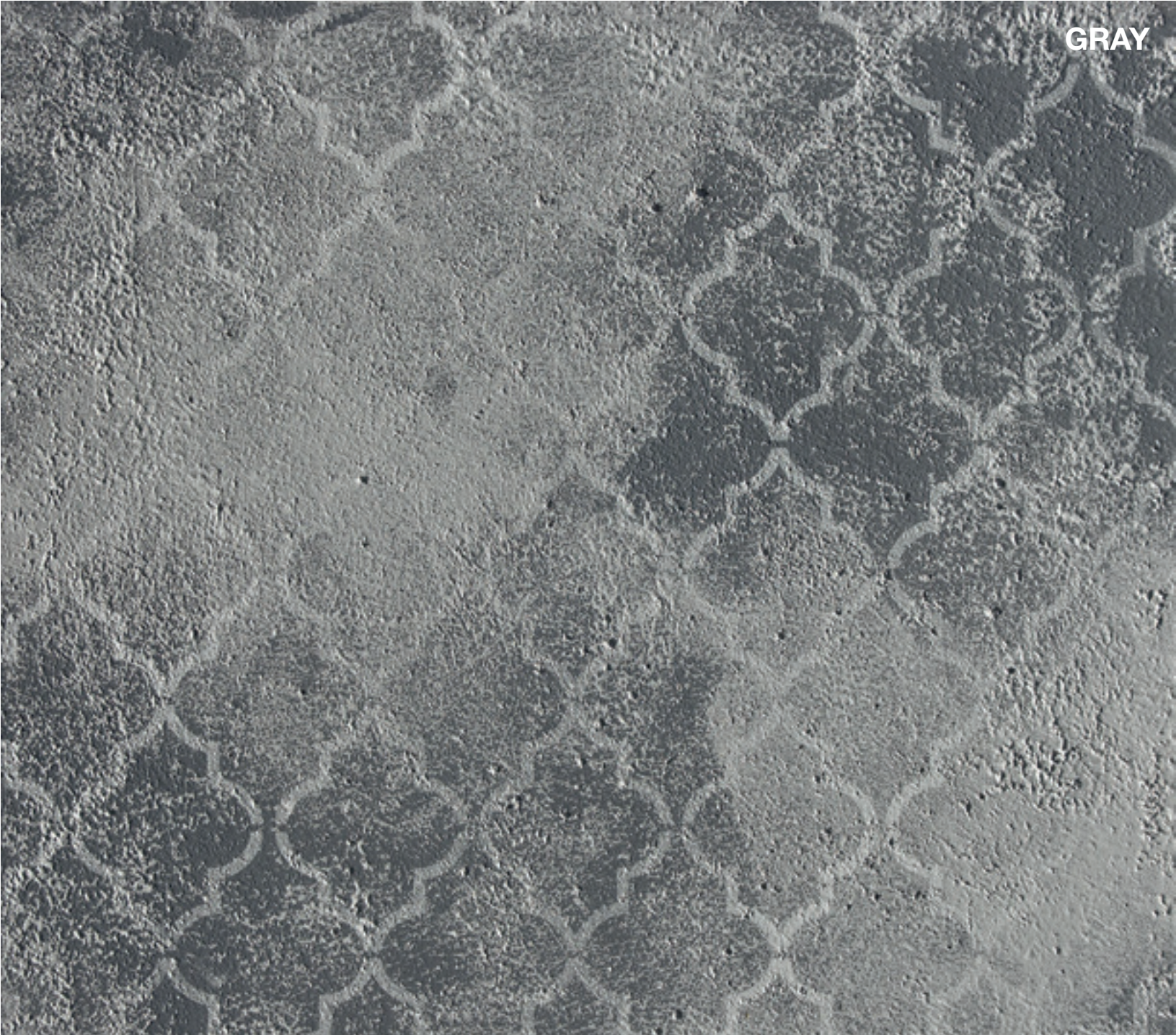

GRAY



204
NATURAL

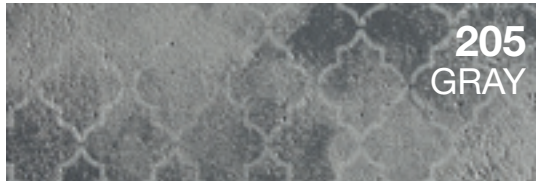

205
GRAY

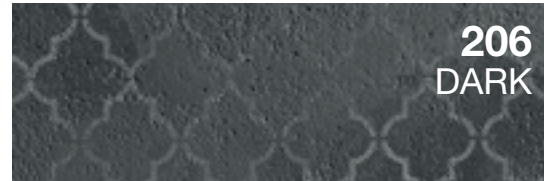

206
DARK

JERSEY



GRAY



204
NATURAL

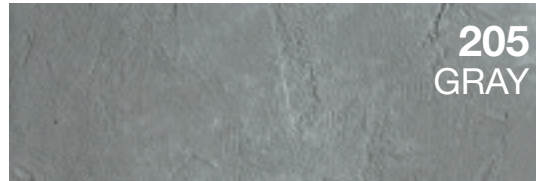

205
GRAY



206
DARK



ARAN

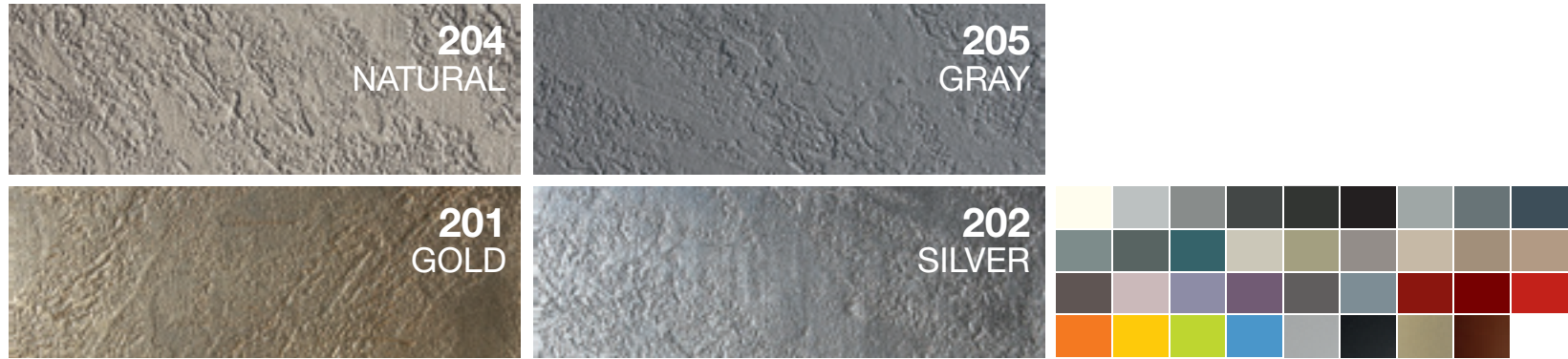
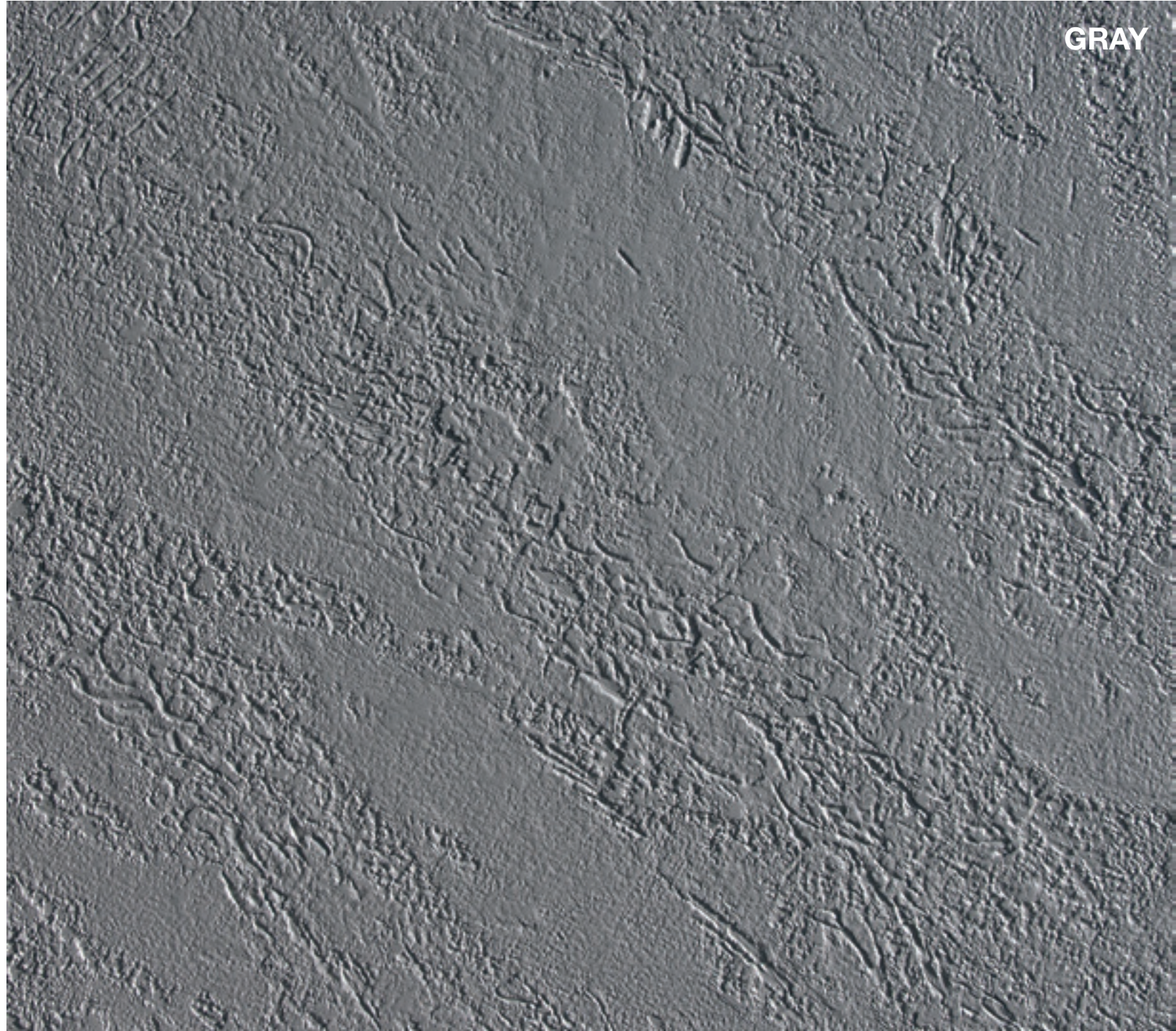

BOUCLÈ

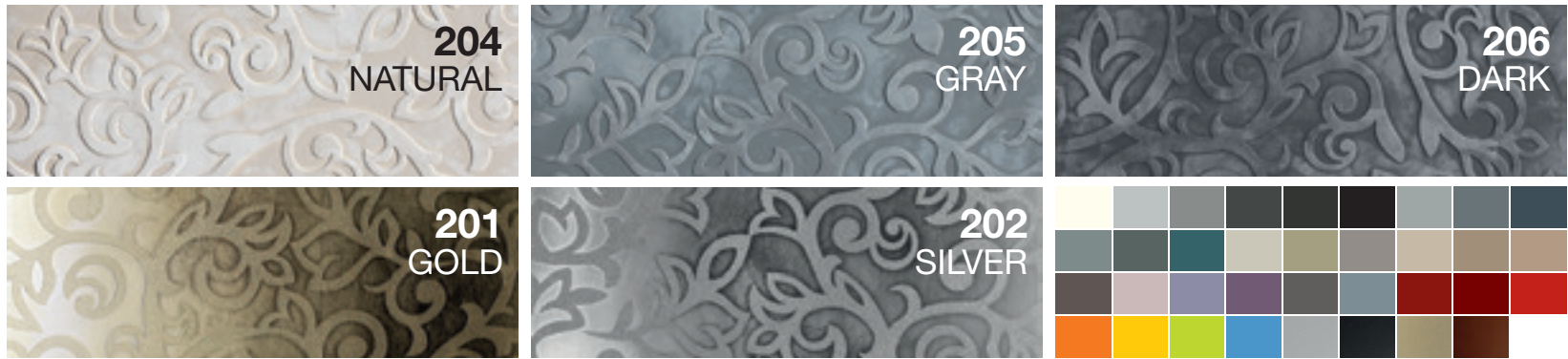

ATELIER

LAMÈ
Technical Data

MATERIALI E FINITURE PER SCOCCHE E FRONTALI

Matériaux et finitions pour caissons et façades / Materials and finishing for cabinets and fronts / Materialien und Ausführungen für fronten und korpus / Materiales y acabados para el cuerpo y los frontales / Материалы и отделки для корпуса и фасадов



B

C

PLUS

Finitura fianco
(il prezzo della finitura è da aggiungere)
Francese Inglese Tedesco Spagnolo Russo

PAG 32

B

GOLD / SILVER

C

LAVORAZIONE ANTA

Finitions bois / Wood finishes / Holzoptik / Esencia / Шпон

GOLD / SILVER
Finitions bois / Wood finishes / Holzoptik / Esencia / Шпон

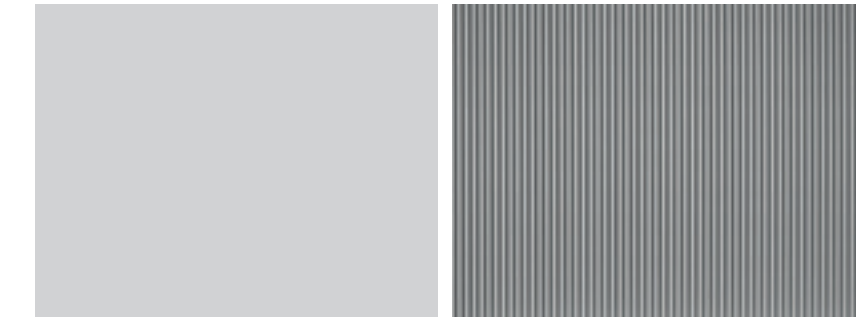

SILK

PLISSÉ

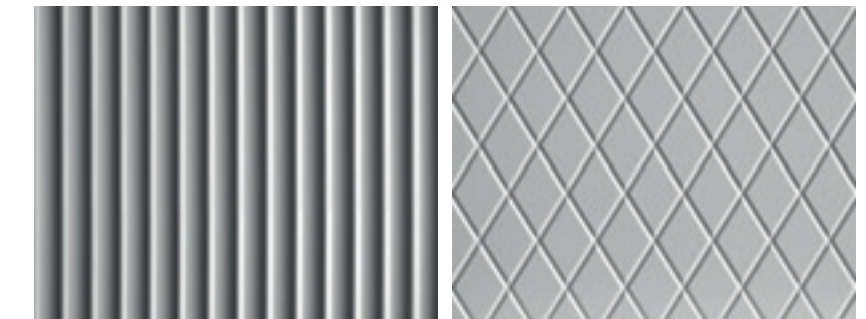

GESSATO

OXFORD

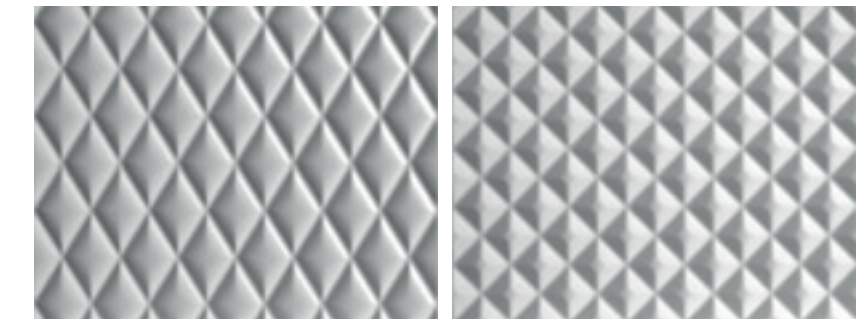

PIQUET

GALLES

MANIGLIA G58

Poignées / Handles / Handgriffe / Manejar / Ручка



201
GOLD



202
SILVER

SILK



COLORI OPACHI/LUCIDI

Finitions bois / Wood finishes / Holzoptik / Esencia / Шпон



PLISSÉ

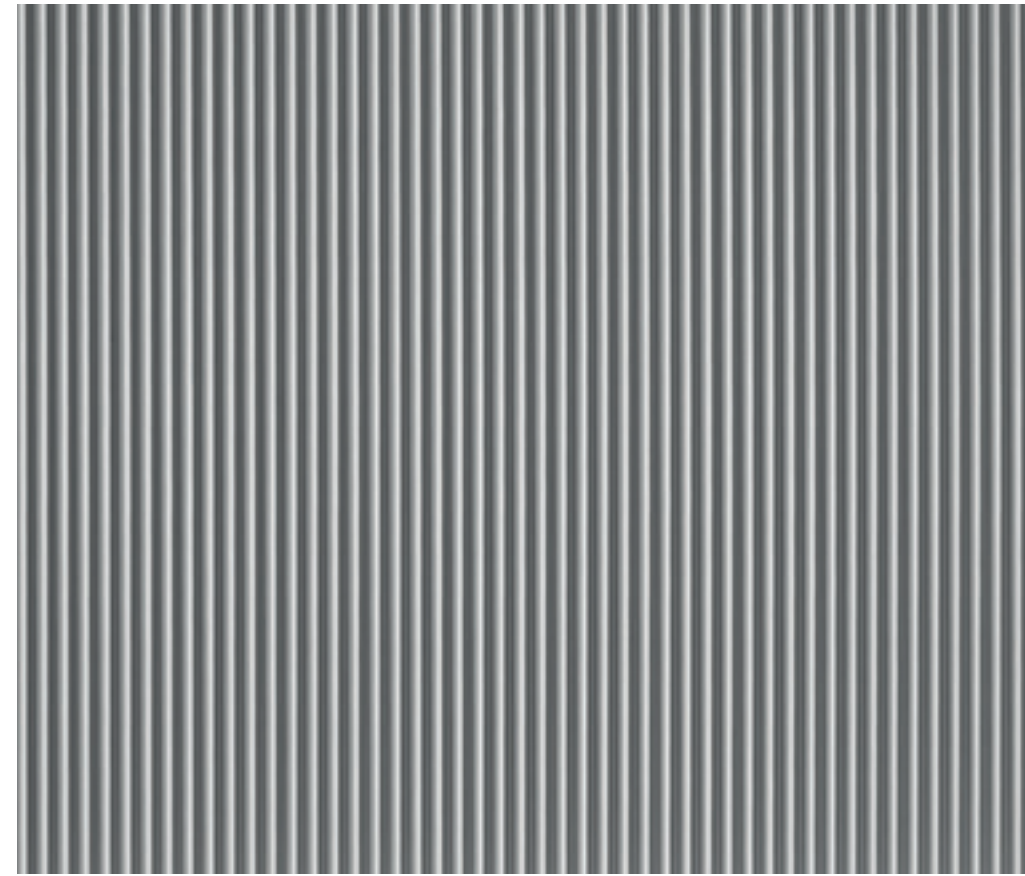

COLORI OPACHI/LUCIDI

Finitions bois / Wood finishes / Holzoptik / Esencia / Шпон



GESSATO

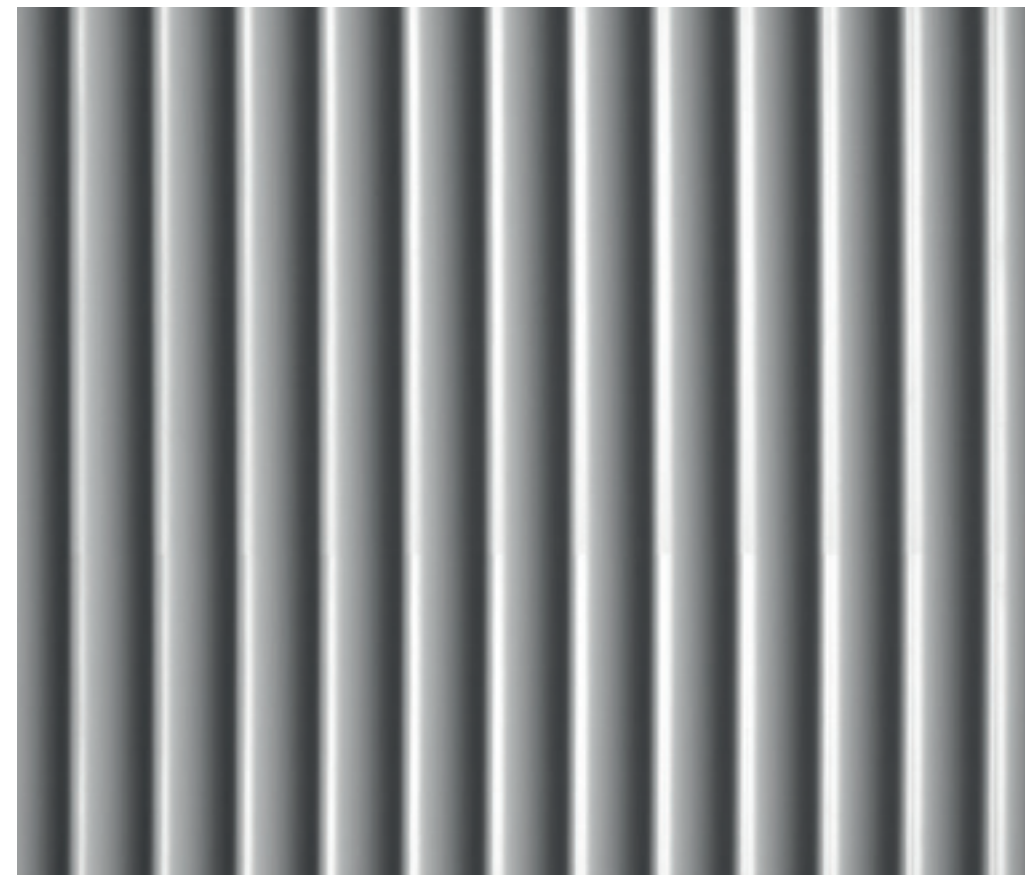

COLORI OPACHI/LUCIDI

Finitions bois / Wood finishes / Holzoptik / Esencia / Шпон



FOGLIA

Finitions bois / Wood finishes / Holzoptik / Esencia / Шпон

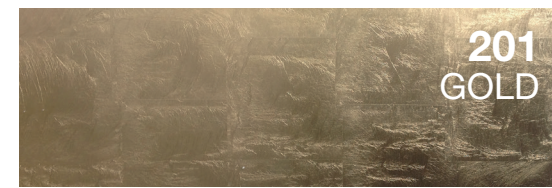

OXFORD

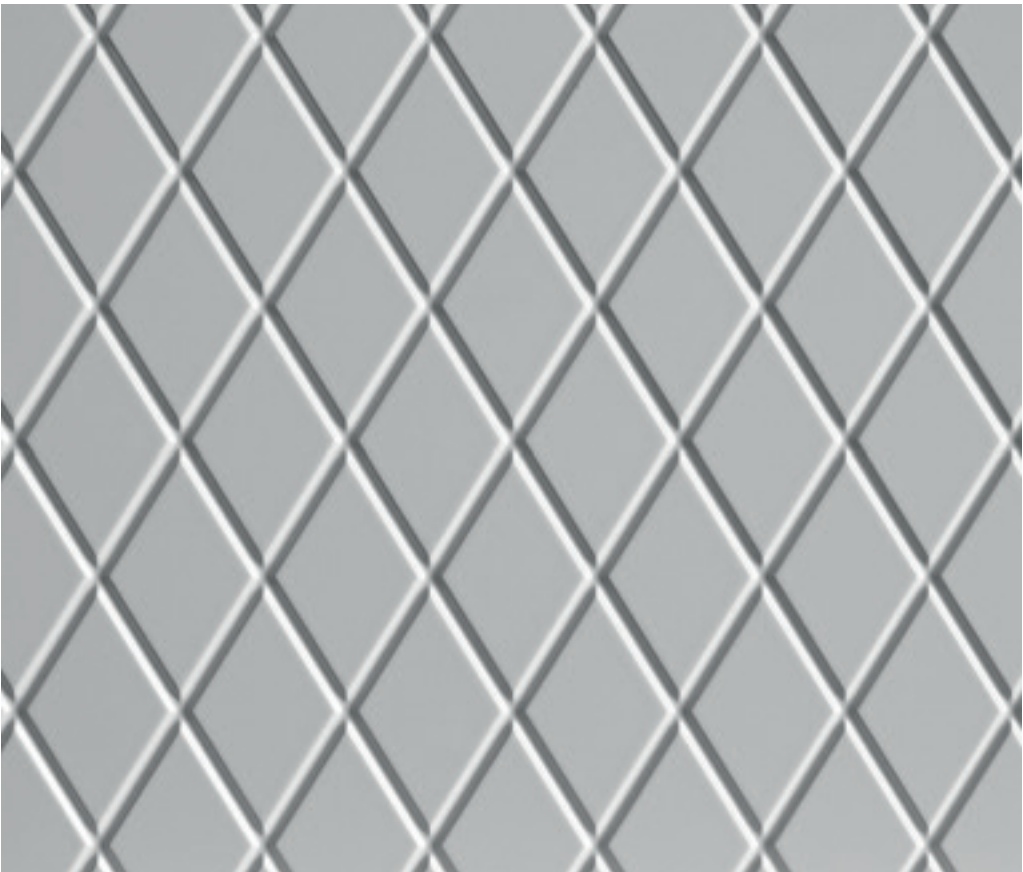

**COLORI
OPACHI/LUCIDI**
*Finitions bois / Wood finishes / Holzoptik /
Esencia / Шпон*



GALLES

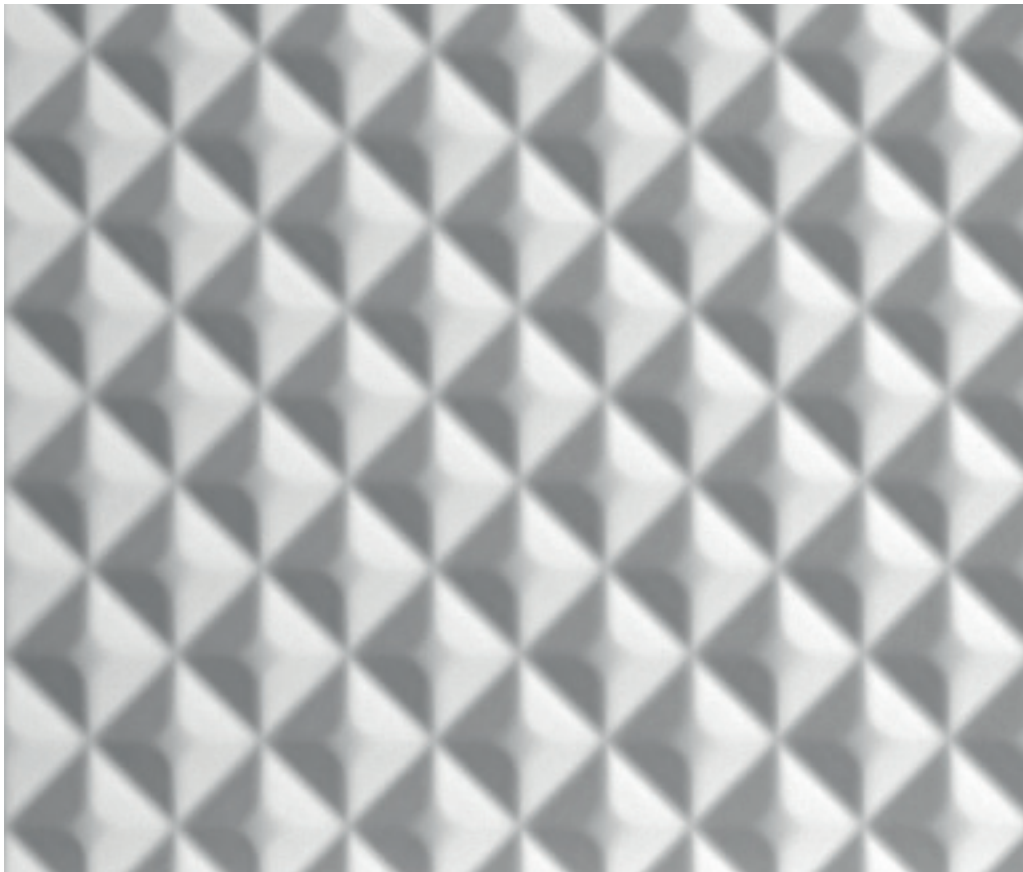

**COLORI
OPACHI/LUCIDI**
*Finitions bois / Wood finishes / Holzoptik /
Esencia / Шпон*



PIQUET



**COLORI
OPACHI/LUCIDI**
*Finitions bois / Wood finishes / Holzoptik /
Esencia / Шпон*



ATELIER

MAKÒ
Technical Data

MATERIALI E FINITURE PER SCOCHE E FRONTALI

Matériaux et finitions pour caissons et façades / Materials and finishing for cabinets and fronts / Materialien und Ausführungen für fronten und korpus / Materiales y acabados para el cuerpo y los frontales / Материалы и отделки для корпуса и фасадов



A

B

A

FINITURE OPACHI / LUCIDI

Couleurs laquées mates, brillantes / Matt Glossy, lacquered colours / Farbblacke Matt, Hochglanz / Colores lacas mate, brillo / Матовые, Глянцевые цвета



B

GOLD / SILVER

GOLD / SILVER



MANIGLIE

Poignées / Handles / Handgriffe / Manejar / Ручка

G50.199
GOLD



G50.199
SILVER



G50.359
GOLD



G50.350
SILVER



G57
GOLD



G57
SILVER

